

BUN PAN RACK

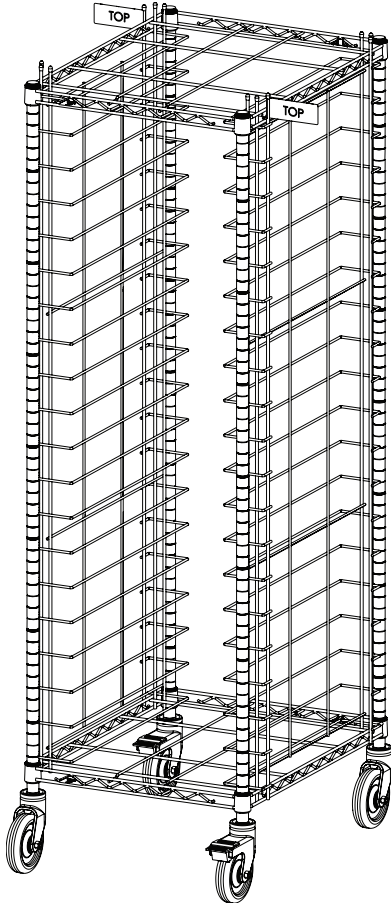

END LOAD
RE1, RE3, RE3S

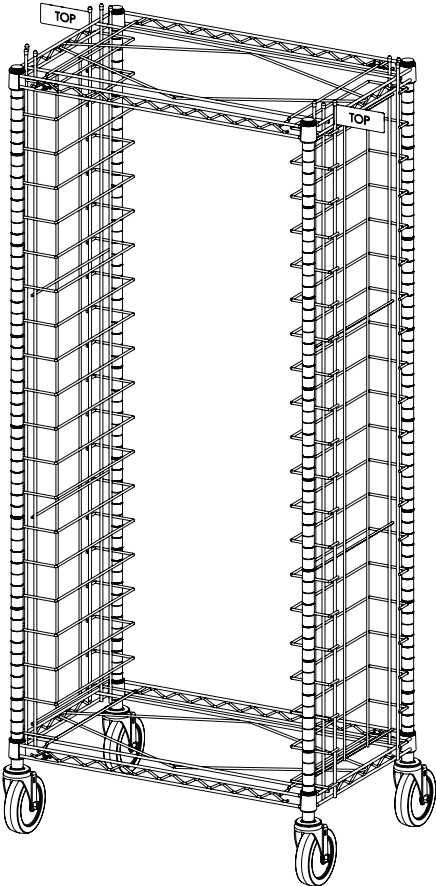

SIDE LOAD
RS1, RS3

How to assemble scan here



TWO PEOPLE REQUIRED TO ASSEMBLE UNIT

1 Press The C-Ring Until The C-Ring Compresses And Fits Inside The Post.

2

3 Sleeve Bead Aluminum Sleeve Bottom Groove

4 Swivel Caster Brake Caster Brake Caster Applicable For RE3S Unit Only RE Shelf Swivel Caster

5 All Corners

6 Wire With Longer End Faces Top Horizontal Wire Must be Face Inside. Wires With Shorter End Face Bottom

7 TOP VIEW Press Down Firmly To Seat In Place Repeat For other side

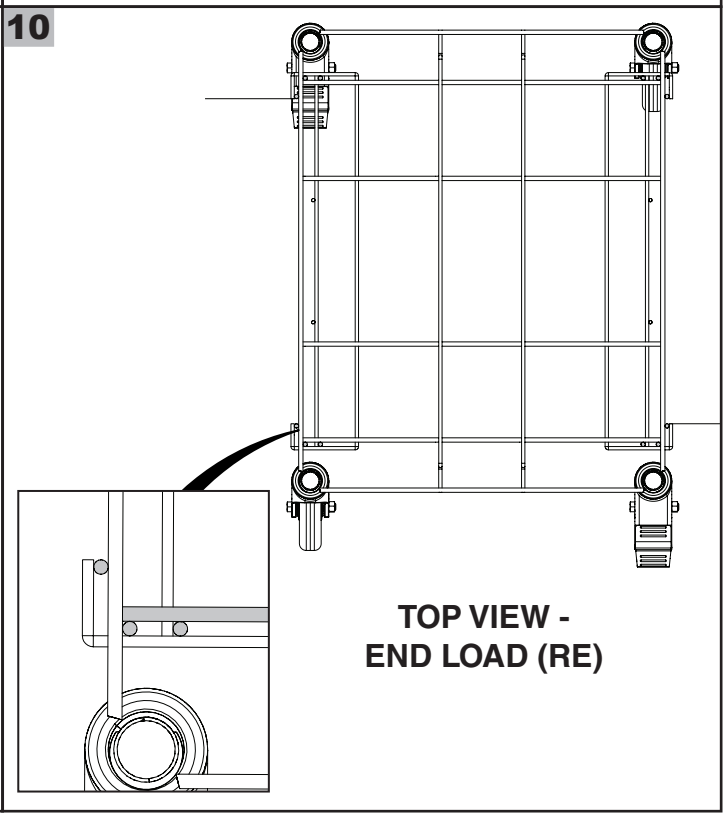
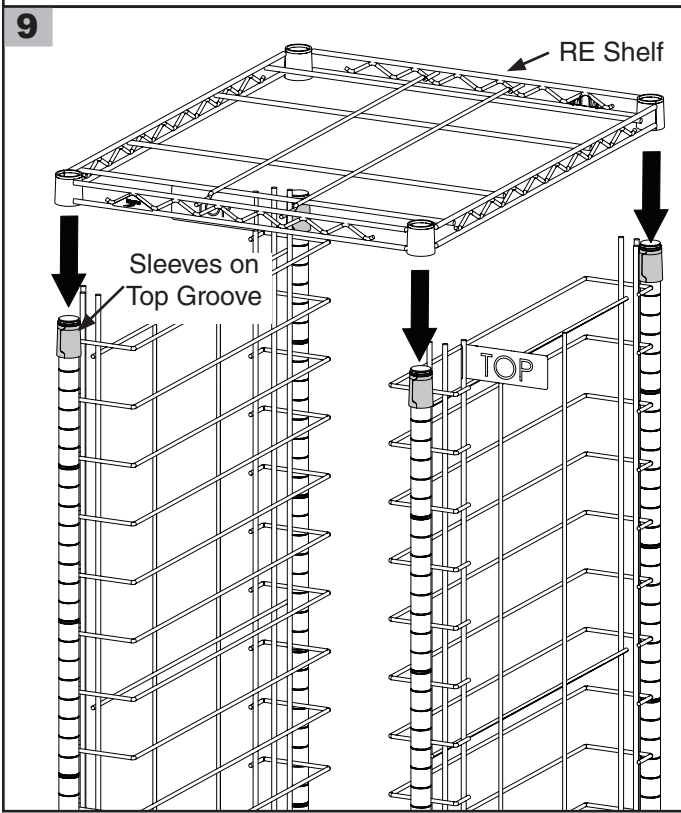
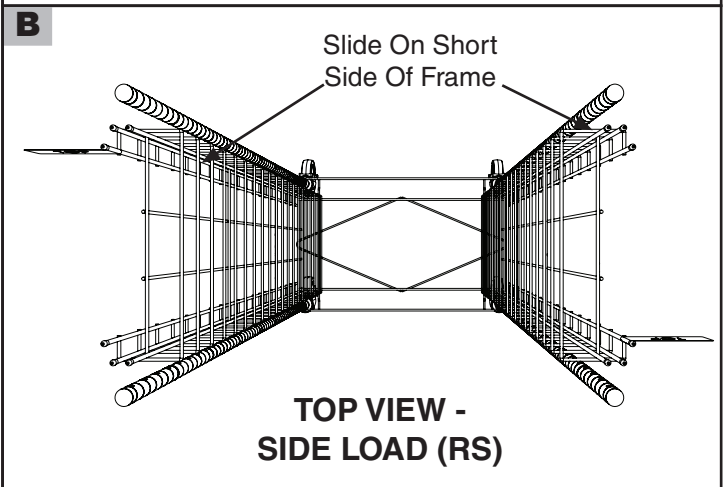
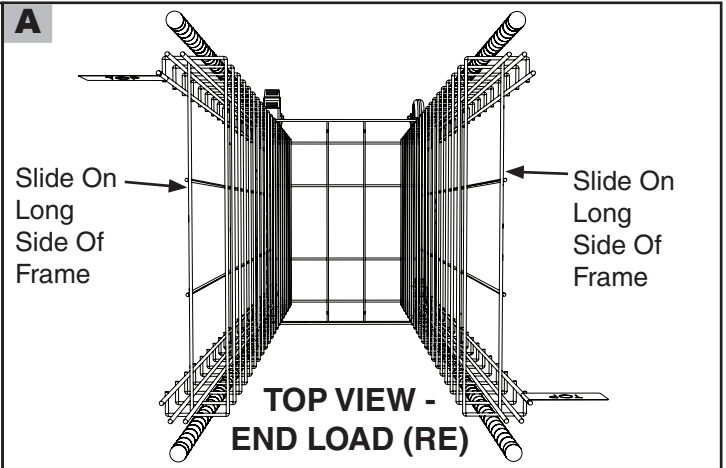
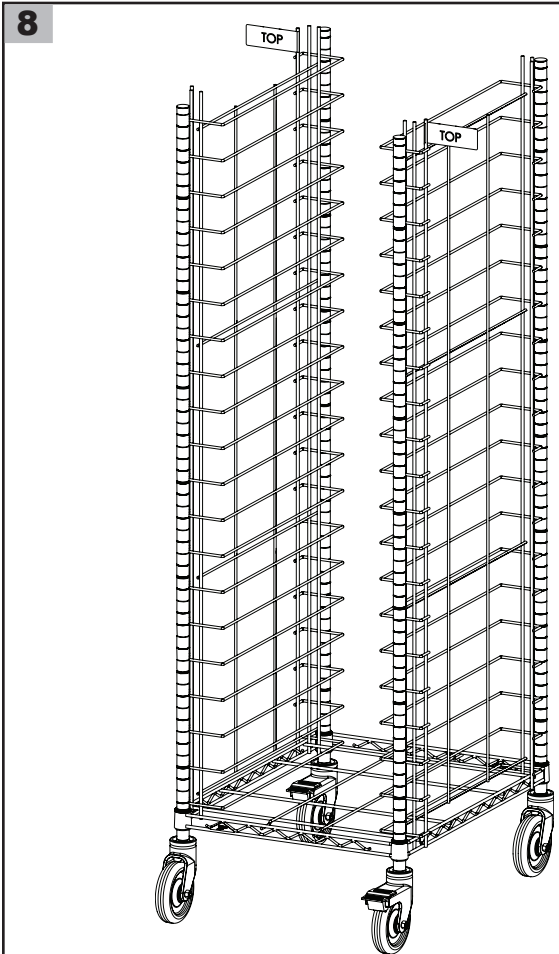

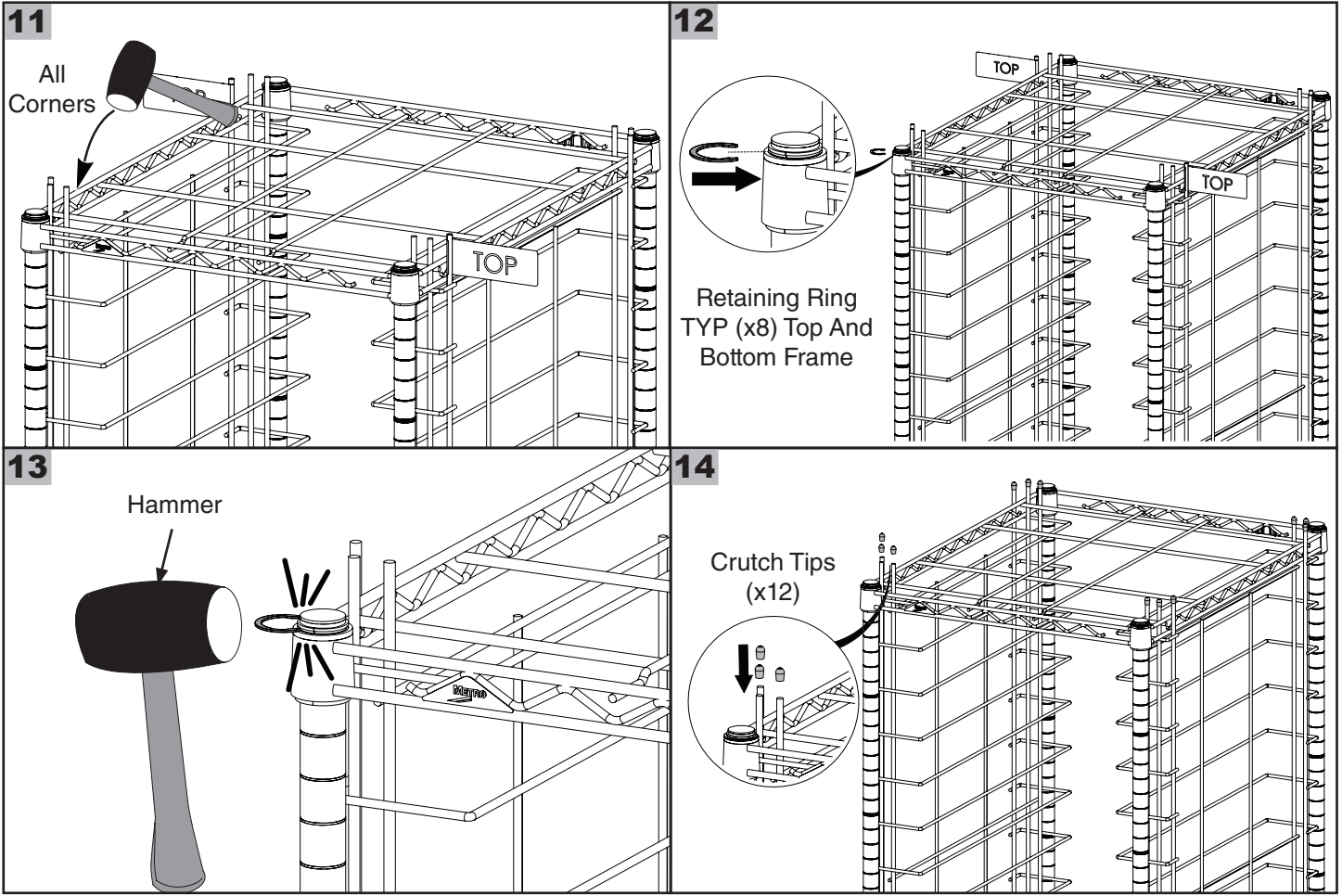

FOLLOW THE SIMILAR STEPS (1 TO 14) TO INSTALL SIDE LOAD

CAUTION: WEIGHT CAPACITY

30 lbs. (13.7kg) per level;
 200 lbs. (90.7kg) per unit



Distribute weight as evenly as possible.

THIS COMPLETES INSTALLATION OF BUN PAN RACK

* Save this document for future application, load rating and/or safety reference.

© 2022 InterMetro Industries Corporation, Wilkes-Barre, PA 18705
 L01-151 REV C 03/22



We put space to work.

an Ali Group Company



The Spirit of Excellence