

# SLANTED SHELF CART

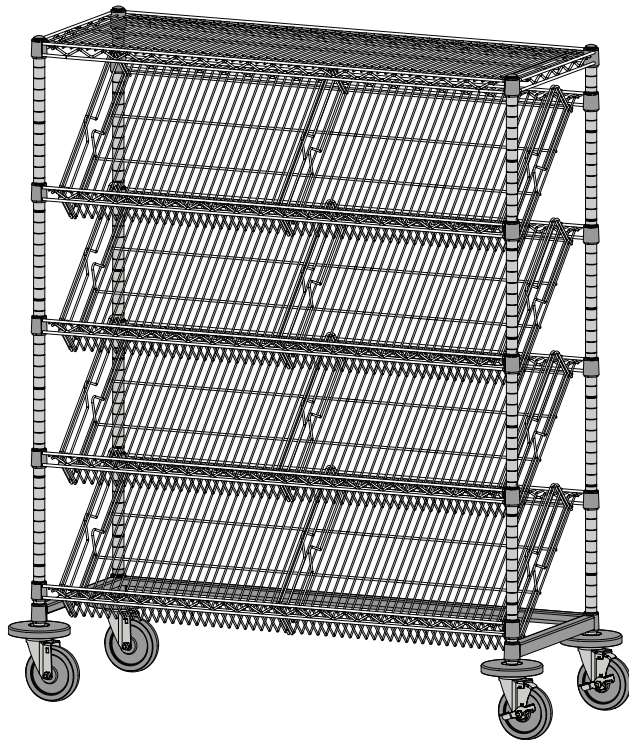

**FOUR SLANTED SHELF UNIT**  
DC15EC, DC35EC, DC55EC

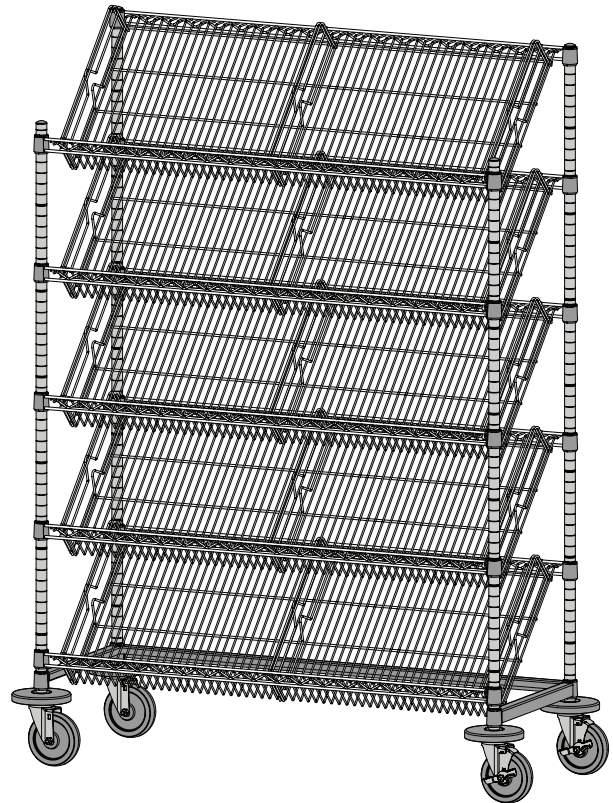

**FIVE SLANTED SHELF UNIT**  
DC16EC, DC36EC, DC56EC

## DESCRIPTION

This instruction sheet covers the assembly procedure for carts utilizing slanted shelves and for specific models: DC15EC, DC35EC, DC55EC, DC16EC, DC36EC, DC56EC.

# SLANTED SHELF CART — INSTRUCTIONS FOR USE

## TWO PEOPLE REQUIRED TO ASSEMBLE UNIT

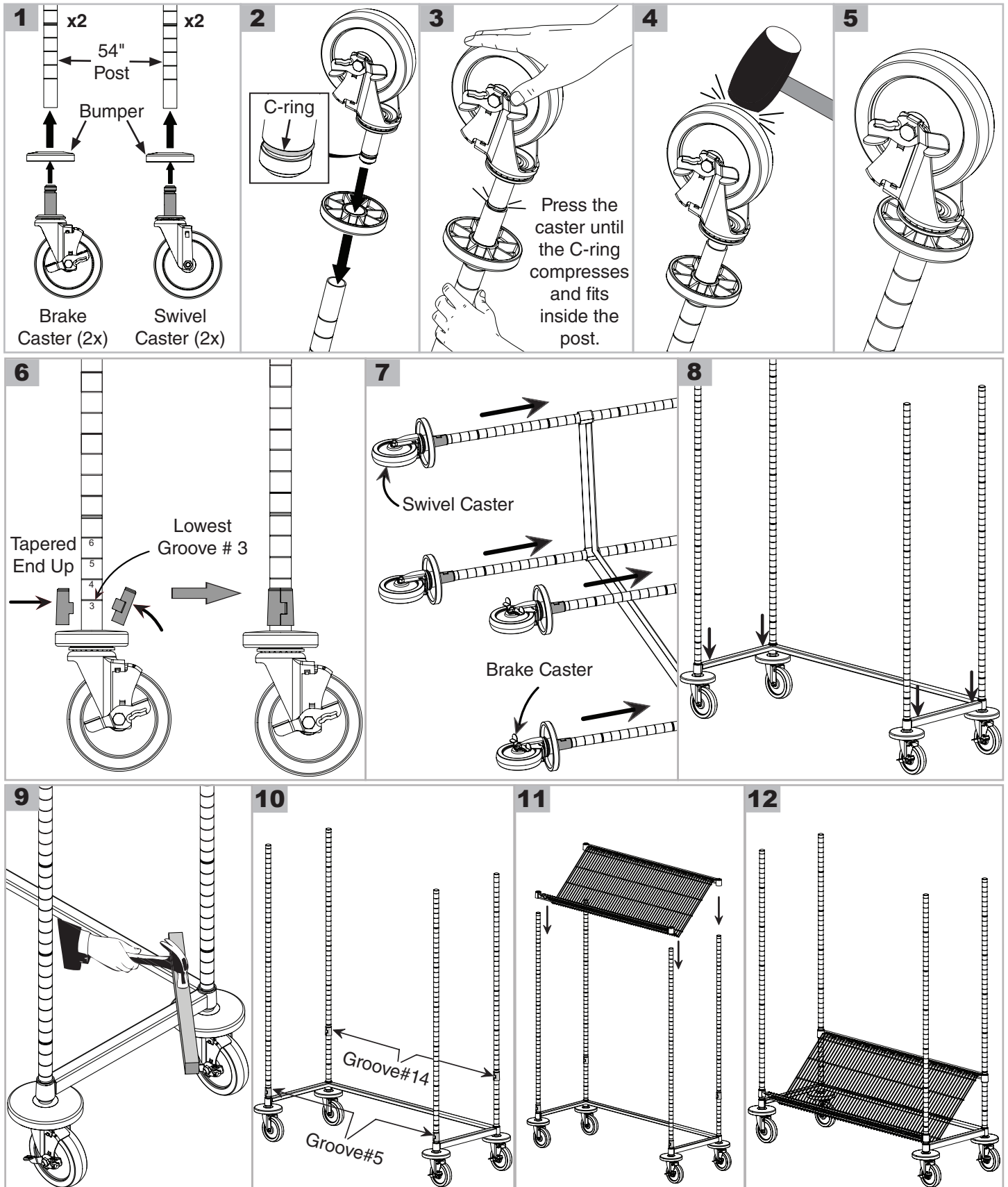

# SLANTED SHELF CART — INSTRUCTIONS FOR USE

**13** REPEAT STEPS 8-9

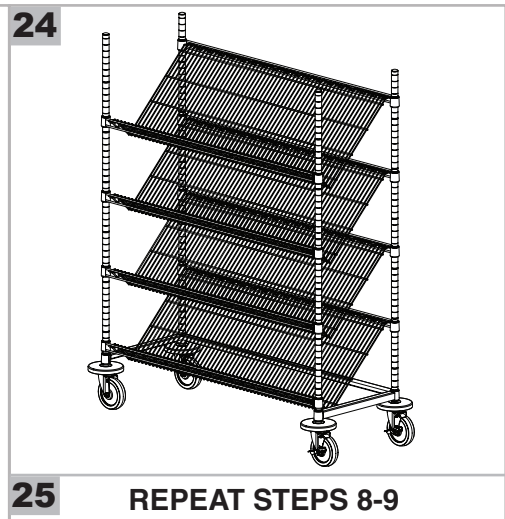
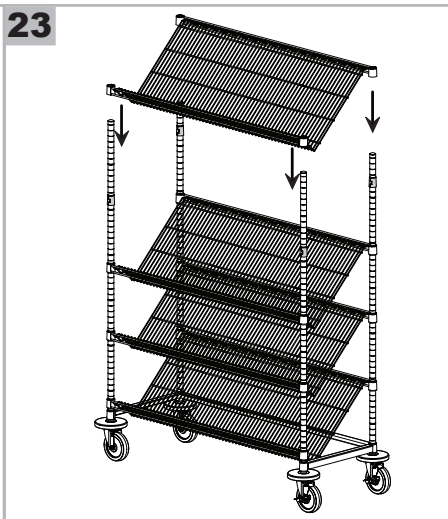
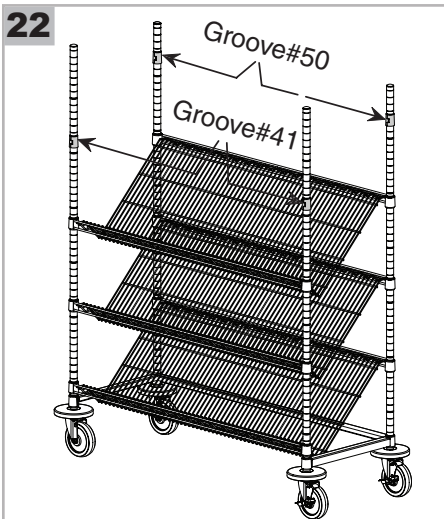
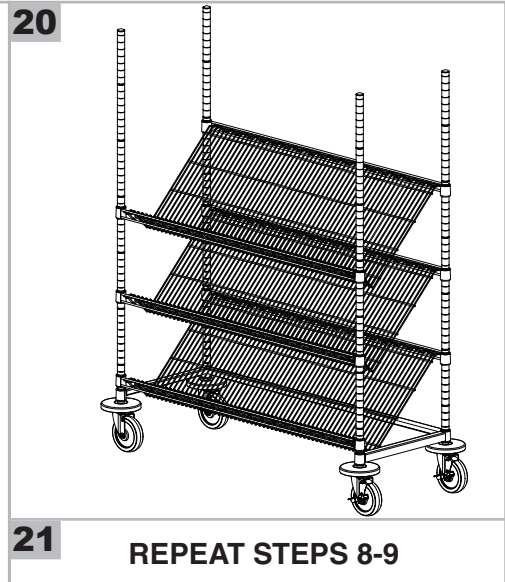
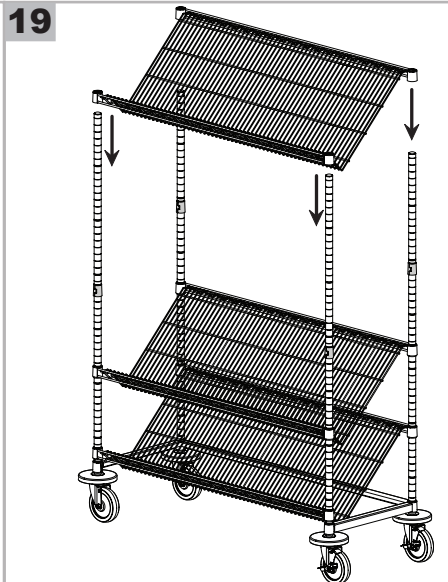
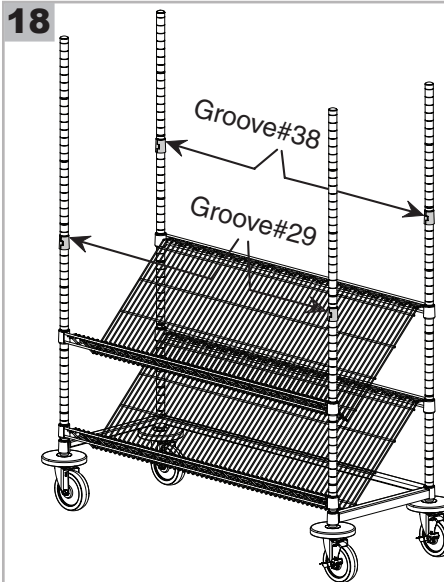
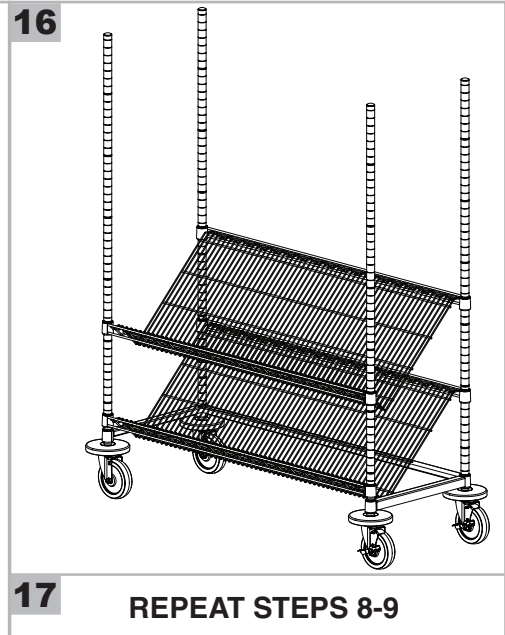
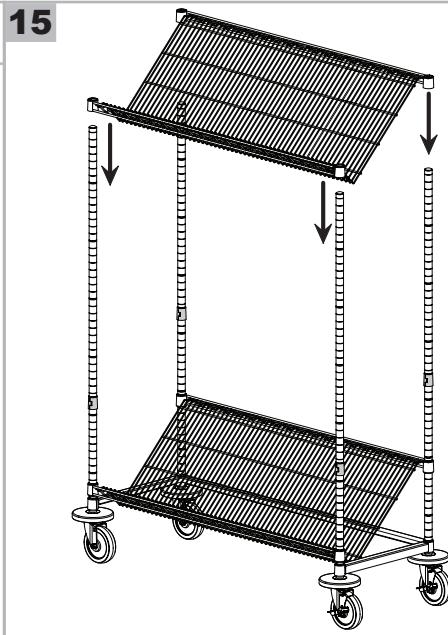
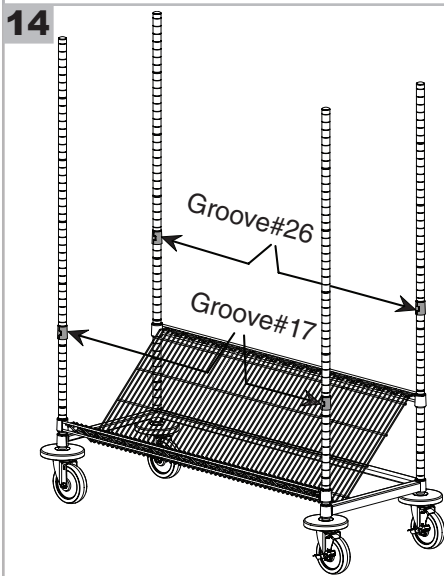

## 26 Four Slanted Shelf

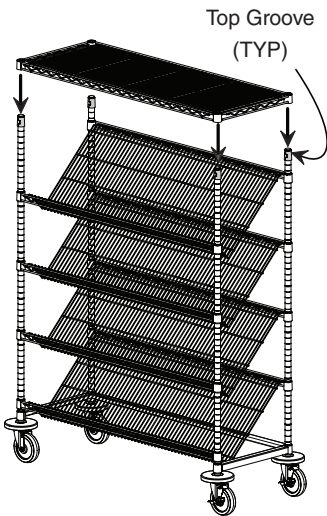

## Five Slanted Shelf

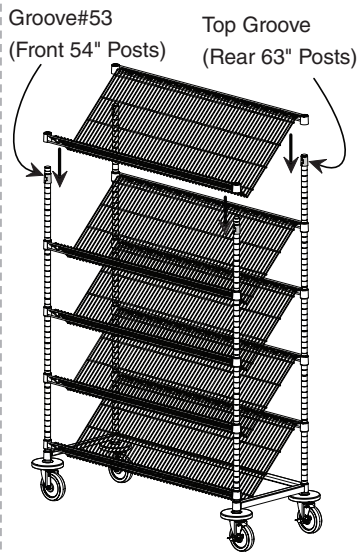

## 27

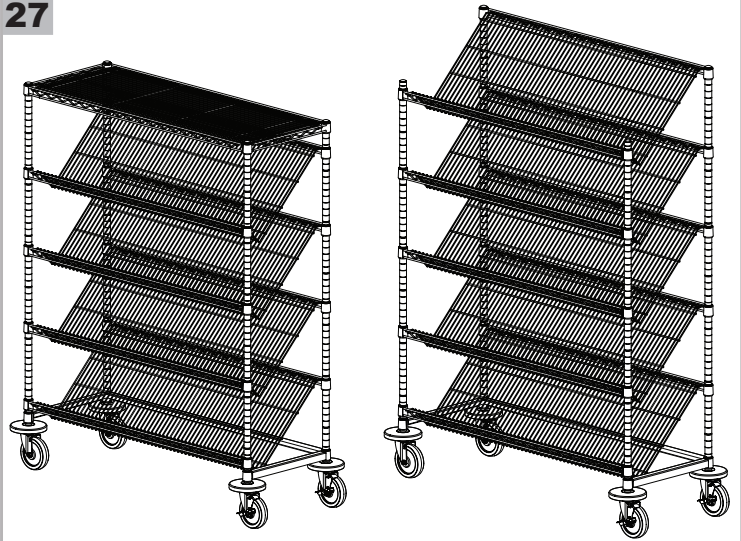

## 28

REPEAT STEPS 8-9

## 29

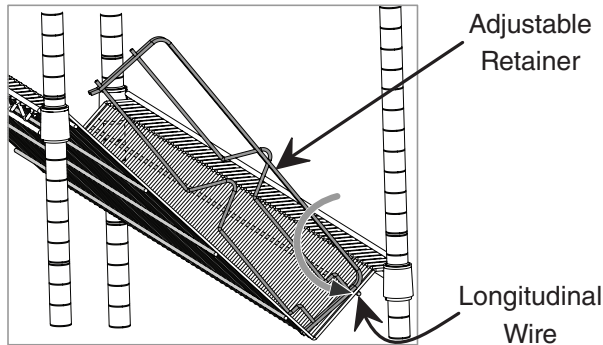

## 30

Squeeze the Retainer at the Center

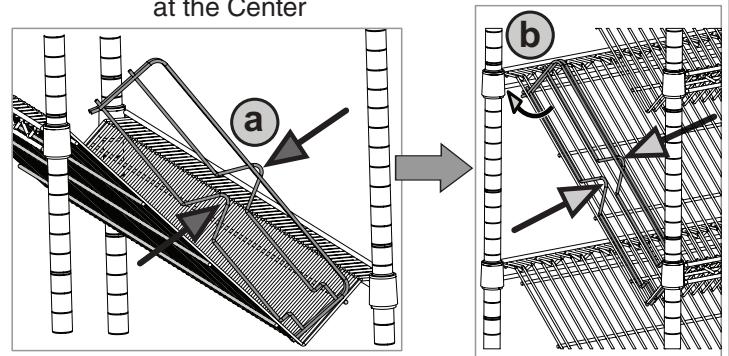

## 31

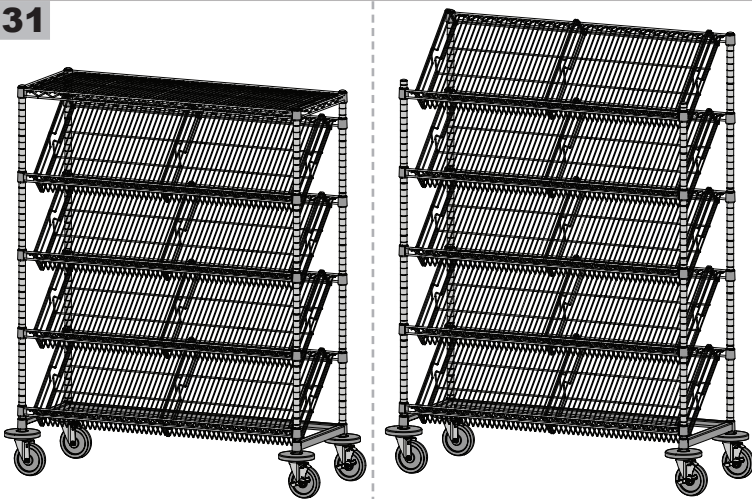

### CAUTION: WEIGHT CAPACITY

Slanted Shelves (all sizes):  
200 lbs. (91 kg.) maximum equally distributed.



**NEVER** exceed 800 lbs. (363 kg.) on any Stationary Storage System.

**NEVER** exceed 400 lbs. (181 kg.) or three times the caster load rating (which ever is less) on any Mobile Storage System.

Distribute weight as evenly as possible.

*Failure to follow these instructions could result in personal injury or property damage.*

**THIS COMPLETES THE ASSEMBLY OF FOUR AND FIVE SLANTED SHELF UNITS**

\* Save this document for future application, load rating and/or safety reference.

© 2021 InterMetro Industries Corporation, Wilkes-Barre, PA 18705  
L01-069 REV C 11/21



We put space to work.

an Ali Group Company



The Spirit of Excellence