

Product Data Sheet

Date of Generation: 06.06.2018

Article-Nr.:	106 478
Type of Product:	SafetyWasteCap, electronic level control, electrostatic conductive, immersed filling lance
Color:	black
Connection:	waste: S55 (f) to GL25(m), vapor: GL14 (f), electronic: M8x1 3-pin (m)
Dimensions (D x W):	ca. Ø65 x 245,5 mm
Weight:	ca. 121 g
Material:	PE-HD
Surface Resistivity:	$10^4 - 10^6 \Omega$

Test Reports / Approvals:		
Report-Nr.	Date	Testing Center
11 204 091853	11.01.2012	TÜV NORD CERT GmbH
		

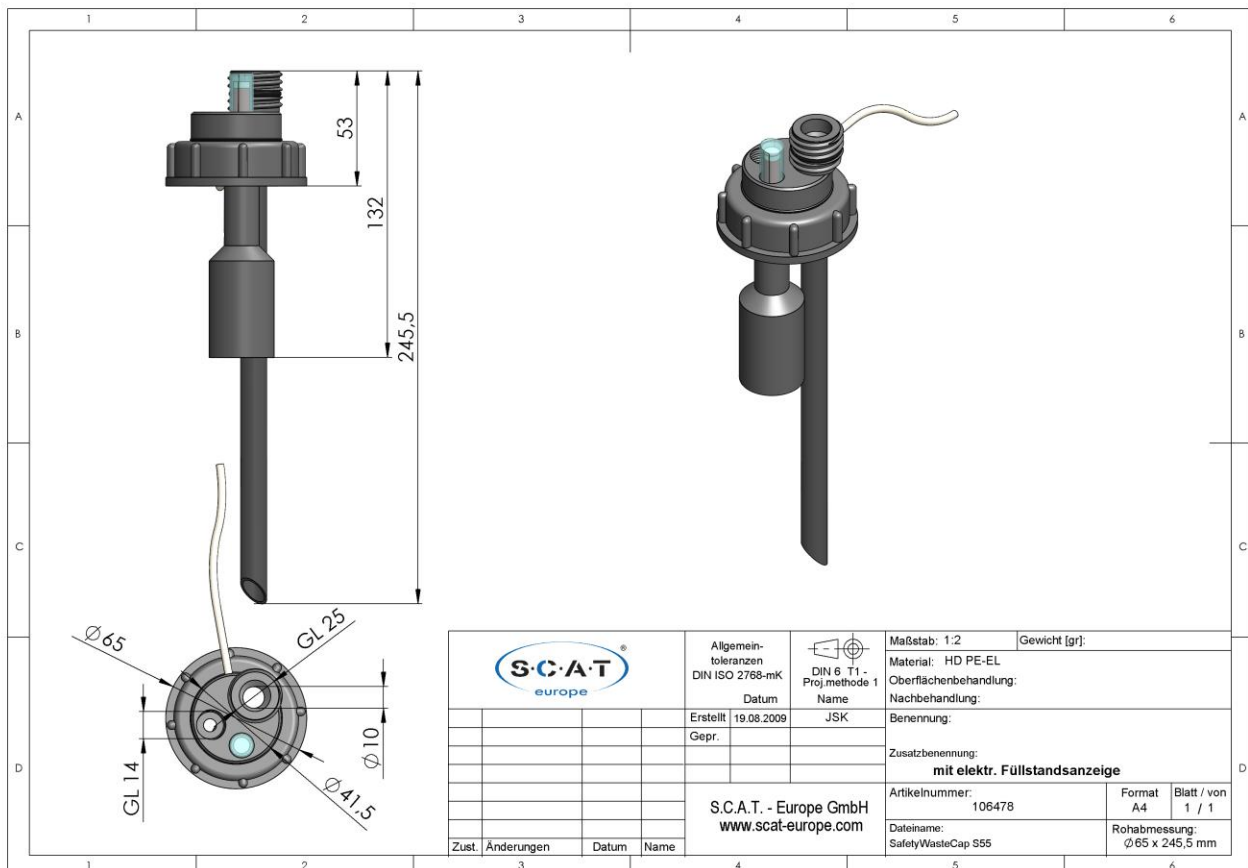

Post-/Lieferanschrift
S.C.A.T. Europe GmbH
Opelstraße 3
64546 Mörfelden
Deutschland

Telekommunikation
Tel.: +49-(0) 6105 - 305 586 - 0
Fax: +49-(0) 6105 - 305 586 - 99
e-Mail: info@scat-europe.com
Web: www.scat-europe.com

Bankverbindung
Volksbank Frankfurt
BLZ: 501 900 00
Konto-Nr.: 600 151 1678
SWIFT: FF VB DE FF

Gesellschaftsinformation
Sitz: 64546 Mörfelden
Amtsgericht: Darmstadt
Handelsregister B, Nr. 55045
Geschäftsführer: Johann Rittgasser